

EMSTAT 4X™

Operator's Manual

02-2026-008



If you have problems

First make sure to check the “Troubleshooting” section in this document and the Knowledge Base on our website: www.palmsens.com/knowledgebase/
This page contains support information on installation, software updates, and training.

Please make sure your software and firmware are up-to-date.



In case of persistent problems:

Use the contact form: www.palmsens.com/contact/

Give us a call: +31 30 2459211

Or send an email: info@palmsens.com

Try to describe the problem as detailed as possible. Sending us the relevant method files, data files and screenshots can be helpful.

Please include your instrument model and serial numbers, as well as any applicable software and firmware version you are using.

Limited Warranty

Except as otherwise provided herein, PalmSens BV warrants to buyer three years from the date title to the product passes (transfer date of goods from seller to buyer), each product sold hereunder will be free of defects in materials or workmanship and will conform to specifications set forth in PalmSens BV’s published data sheets or, where applicable, user manuals for PalmSens BV’s system products in effect at the time title passes.

PalmSens BV’s sole liability and responsibility for products under this warranty is for PalmSens BV to repair or replace any product that is returned to it by buyer or credit buyer’s account for such returned product, provided that PalmSens BV shall have the right to reject any such remedy where PalmSens BV determines that the warranty does not apply. Products returned to PalmSens BV for warranty service will be shipped to PalmSens BV at buyer’s expense and will be returned to buyer at PalmSens BV’s expense. PalmSens BV’s obligation to honor its warranty for a product is contingent upon receipt of payment in full for such product.

See our website for more detailed information:

www.palmsens.com/terms-and-conditions/

Disclaimers

PalmSens BV is not liable for any direct, indirect, incidental, or consequential damages resulting from the use or misuse of its instruments, including but not limited to:

- Damage to the instrument caused by improper handling, unauthorized modifications, or use outside the recommended specifications.
- Malfunction or incorrect results due to improper sample preparation, contamination, or incorrect experimental setup.
- Loss of data or research results caused by software crashes, hardware failures, or power interruptions.
- Personal injury or property damage resulting from incorrect wiring, exposure to hazardous chemicals, or misuse of electrical connections.

Results obtained using PalmSens instruments depend on experimental conditions, sample properties, and user expertise. Users are responsible for verifying the validity of their data.

Changes in specifications and typing errors reserved. Every effort has been made to ensure the accuracy of this document. However, no rights can be claimed by the contents of this document.

By using PalmSens instruments, the user acknowledges and accepts these limitations and responsibilities.

See Appendix A for CE declaration of conformity.

Copyrights

EmStat4X Operator's Manual.

Copyright © 2024-2026, PalmSens BV, all rights reserved.

PSTrace, MultiTrace, Nexus, PalmSens, EmStat, MultiEmStat and Sensit are trademarks of PalmSens BV.

No part of this document may be copied or reproduced in any form without the prior written consent of PalmSens BV.



Contents

1	Introduction.....	1
1.1	The scope of this manual	1
1.2	About the EmStat4X	2
2	Operating the EmStat4X.....	3
2.1	USB and charging	3
2.2	Bluetooth.....	3
2.3	Cell connections.....	4
2.4	Display and status LED indicator	4
2.5	iR Compensation	6
2.6	Auxiliary port pin-out	7
2.7	Cell connector pin-out.....	8
2.8	SPE connector	8
3	Battery replacement.....	11
4	Specifications.....	13
5	Troubleshooting	15
5.1	Verifying your potentiostat.....	15
5.2	Noise.....	16
6	Maintenance and compliance	19
6.1	Lithium-Polymer batteries.....	19
6.2	Temperature compliance.....	19
6.3	Humidity compliance.....	20
6.4	Temperature drift.....	20
6.5	Atmospheric pressure.....	20
6.6	Cleaning.....	20
6.7	Periodic calibration and preventive maintenance.....	20
6.8	Service and repair.....	20
6.9	RoHS Compliance.....	20
A.	EU Declaration of conformity.....	21
B.	EU Waste Electrical and Electronic Equipment (WEEE) Directive	22

1 Introduction

1.1 The scope of this manual

This manual covers the handling, characteristics, troubleshooting, and other practical information regarding the hardware specifics of the EmStat4X, as well as maintenance and compliance.

Please refer to the **Quick Installation Guide** that was supplied with the instrument for instructions on installing the instrument and the software. Additionally, the section **Getting Started** in the digital **PSTrace Manual**, that is installed with the software, provides detailed instructions for conducting first measurements with your instrument.



Initial setup and basic operational instructions for conducting initial measurements are detailed in the “Quick Installation Guide” supplied with the instrument.

The PSTrace Manual is an in-depth document covering not only the PSTrace software but also the hardware limitations for each technique supported by the instrument. It is written to give you a full understanding of both the software and hardware aspects, making sure you're well-equipped to use all the functionalities of the EmStat4X.

1.2 About the EmStat4X

The EmStat4X LR and HR are on the market since 2023. They are the successor of the EmStat3 Blue and 3+ Blue. Like the EmStat4S, the EmStat4X comes in two different versions: the Low Range (LR) and High Range (HR) version.

- Low Range: for lower currents and potentials. This version can be identified by its blue bottom shell.
- High Range: for higher currents and potentials. This version can be identified by its black bottom shell.



Figure 1 The EmStat4X LR (left) and EmStat4X HR (right)

2 Operating the EmStat4X

The EmStat4X can be used either on battery using a wireless Bluetooth connection or by connecting it via its USB-C port to a PC or Android device. A single touch button next to the display can be used to switch the instrument on and off again. Put your finger on the button (no force needed) and hold it for a few seconds to turn in the instrument on. Do the same for turning the instrument off again.

2.1 USB and charging

The EmStat4X has a USB Type-C (USB-C) port and uses the High-Speed USB 2.0 specification. The EmStat4X can be used with any USB port.

For optimal performance, PalmSens recommends using only the shielded USB-C to USB-A (standard rectangular plug) cable supplied as standard with the instrument. Use of other or longer cables may increase susceptibility to electromagnetic interference and may affect measurement performance. Similarly, if feasible, it is recommended to refrain from utilizing a USB hub or docking station.

Please note that not all USB-ports can provide enough power to prevent discharging the battery when using the EmStat4X HR at the highest current range. In order to prevent the EmStat4X HR battery to discharge when using the 100 mA range, please make sure to use the USB-C cable as provided connected to a USB-C port of the PC.



The EmStat4X requires to be connected to a USB-C charger or host for charging with the maximum current of 1 A.

When the EmStat4X is connected to a USB-C charger or host, charging the battery from depleted to full takes less than 3 hours. With the instrument being powered off or connected to another type of USB port, the charge current is maximum 500 mA.

2.2 Bluetooth

Every EmStat4X has a unique Bluetooth identifier. The Bluetooth identifier of the EmStat4X instrument can be found on the display when the instrument is idle. The Bluetooth identifier always starts with the letters PS, followed by the last 4 characters of its MAC address. For example: PS-6AEF.

When connecting to the USB port of a PC, Bluetooth will switch off automatically unless there is a Bluetooth connection active. This allows the instrument to be charged via the PC while a Bluetooth connection is present.

See also section: "Connecting using Bluetooth" in the PSTrace Manual.

2.3 Cell connections

The cell cable is connected to the EmStat4X by means of a LEMO push-pull connector. Make sure the red dot on the connector is facing upwards when plugging the connector into the EmStat4X.

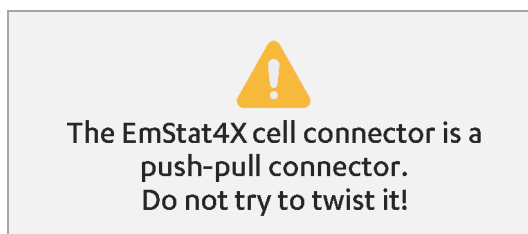
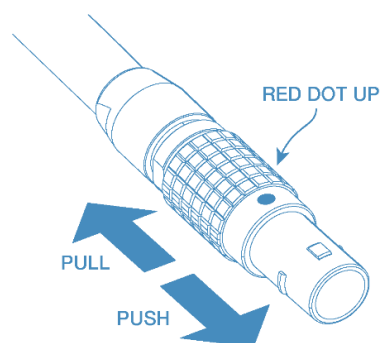

The EmStat4 HR version comes with an additional Sense lead. In contrast with the EmStat3+, the Sense lead of the EmStat4S HR is active for every current range and should always be connected. This allows the Sense lead to be used in four-electrode measurements.

For more information about making a connection to the cell, see also section: "Connecting a cell to the potentiostat" in the PSTrace Manual.

2.4 Display and status LED indicator

The EmStat4X has a small monochrome OLED display and a multi-color status indicator. The following table explains the meaning for each color.

Table 1 *EmStat4X status led indicator*

Color	State
Steady green	Booting
Steady blue	Cell off (open circuit)
Steady red	Cell on
Blinking green	Uploading new firmware
Blinking orange	Error state
Blinking red	Fatal error (not responding)

Display

The EmStat4X display shows the following information:

- Battery status
- Bluetooth identifier
- Connection status
- Firmware version during boot

2.5 iR Compensation

The EmStat4X iR Compensation module works using Positive Feedback. This is achieved using a 12-bit MDAC in the module which scales the output of the current follower opamp to provide a positive feedback voltage that is proportional to the current through the cell. The compensation voltage is added to the summing point before the control amplifier and thus increases the applied potential to counteract the iR drop.

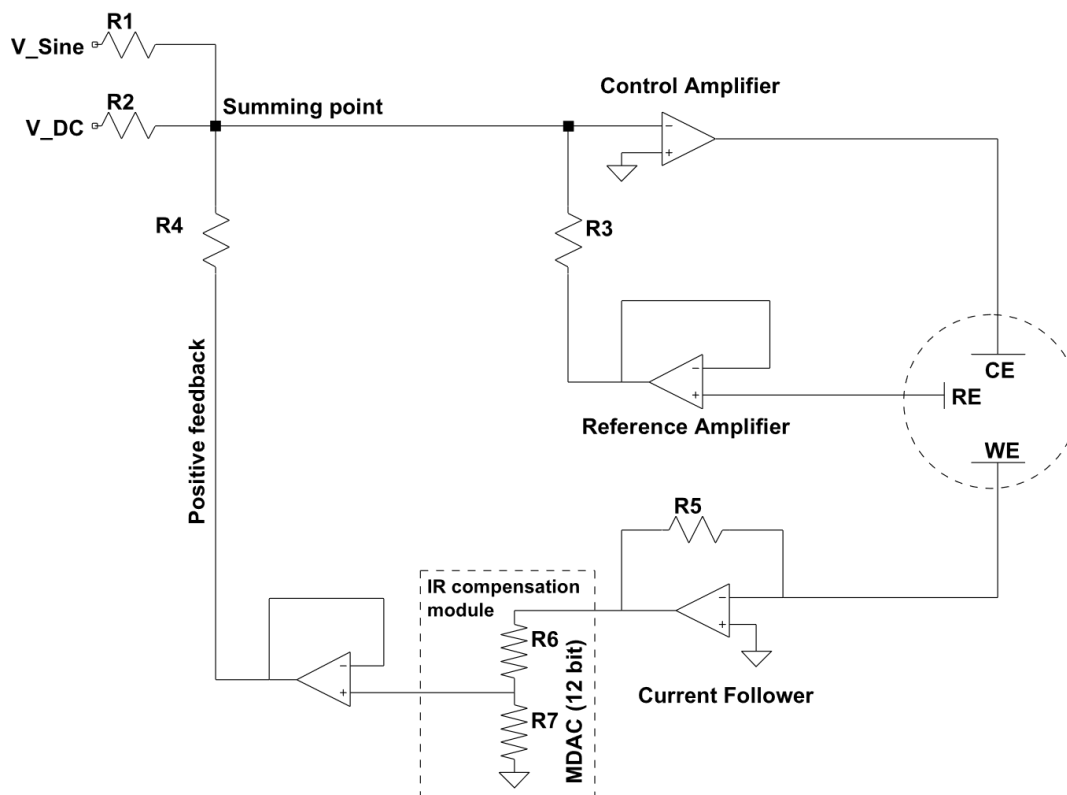

Figure 2 Simplified schematical representation of iR compensation circuitry in the EmStat4X

Positive feedback allows for fast scan rates up to 10 V/s, depending on the characteristics of the cell. If the potential error to compensate for becomes close to the value set for E applied, the system might become unstable. Using iR compensation limits the measurement bandwidth to 160 kHz.

See also section: “Ohmic (iR) compensation” in the PSTrace Manual, and our application note: “iR Compensation and Uncompensated Resistance”.

2.6 Auxiliary port pin-out

The following schematics and table show the EmStat4X auxiliary port pin-out and pin functions.

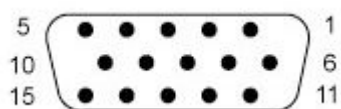

Figure 3 The front view of the female port (DE-15)

Table 2 EmStat4X auxiliary port pins

Pin	Function
1	d0 digital output (3.3 V) *
2	d3 digital output (3.3 V) *
3	auxiliary analog input -10 to +10 V, 16 bit, >0.5 MOhm input impedance
4	RESERVED
5	RESERVED
6	d1 digital output (3.3 V) *
7	d0 digital input (3.3 V) *
8	i monitor given as V in active current range. (-5 to +5 V for LR and -8 to +8 V for HR) The following ranges give an output that is divided by 10. LR: 1 mA, 10 uA, 100 nA, 1 nA HR: 1 mA, 10 uA, 100 nA
9	5V digital power line (max. 300mA)
10	digital ground
11	d2 digital output (3.3 V) *
12	d4 digital input / output (3.3 V) * configurable through MethodSCRIPT
13	E monitor, scaled to a voltage between 0 and 3 V, centered around 1.5 V, where: LR: $VRE = -2.1 * (VAUX - 1.5)$ HR: $VRE = -4.2 * (VAUX - 1.5)$
14	analog ground
15	auxiliary analog out (0 to 6 V at 12 bit)
Connector housing	digital ground

* All digital outputs have a 470 Ohm series resistance.



Ceramic substrates can have very sharp edges that might damage the SPE connector.



When inserting a Screen-Printed Electrode (SPE), avoid touching the electrode areas. Finger contact can contaminate the surfaces and degrade measurement quality. The electrodes also connect directly to sensitive instrument inputs, and touching them may cause electrostatic discharge (ESD) that can damage the circuitry.

Handle the sensor only by its non-electrode edges and ensure you are discharged before insertion

3 Battery replacement

Required:

- Screwdriver: Torx 8
- A 3000 mAh LiPo battery acquired from PalmSens BV

Step 1: Open the battery compartment

Unscrew the four screws and remove the battery lid and gasket. Then gently pull on the battery connector to disconnect it.

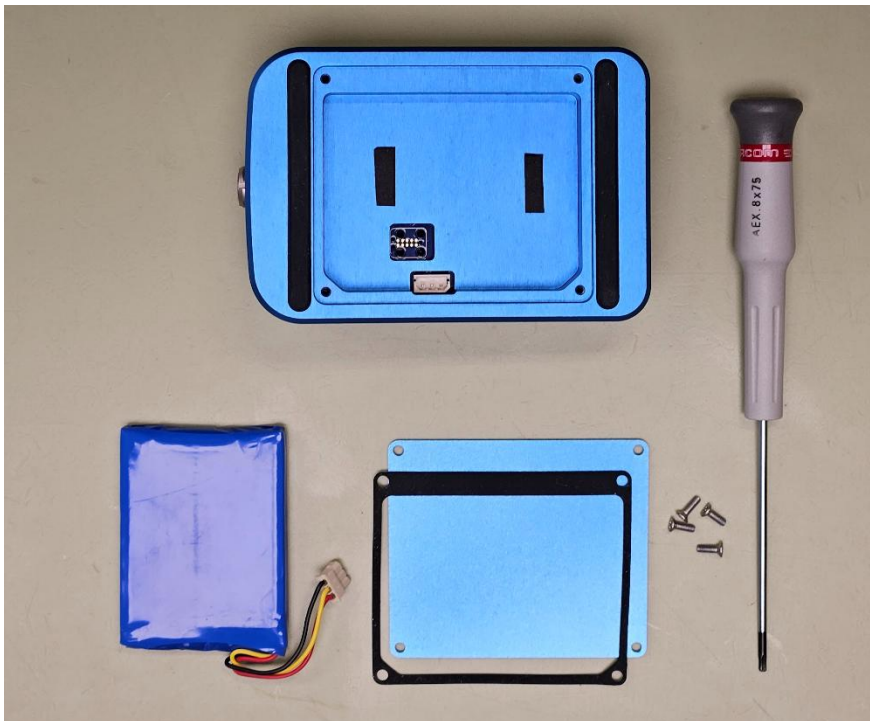

Figure 5 *EmStat4X with the battery lid removed.*

Step 2: Place the new battery

Connect the new 3000 mAh battery as received from PalmSens BV and place it in the battery compartment with the wires folded at the side of the battery.



The use of an unauthorized battery may compromise safety, pose a risk of fire, and result in irreversible damage to the device.

Step 3: Close the housing

Put the lid and the gasket back in place and close the housing. Double-check that the rubber gasket is placed in the right orientation to ensure proper sealing. Do not use excessive force when tightening the screws.

4 Specifications

The EmStat4X LR and HR instruments have similar specifications as the regular EmStat4S LR and HR, but they are extended with a display, Bluetooth connectivity, a battery and auxiliary port. The table below shows the main differences between the two versions.

Table 5 *EmStat4X specifications*

EmStat4X model differences		
model	LR	HR
▪ electrode connections	WE, RE, CE, and ground, with 2 mm banana plugs	WE, RE, CE, S and ground, with 2 mm banana plugs
▪ power consumption	Typical: 1W (idle) Max: 1.6W (cell on at 30 mA)	Typical: 1.5W (idle) 1.6W (cell on at 10 mA) Max: 4.6W (cell on at 200 mA)
▪ temperature range	0 °C to +45 °C	
▪ power source	USB-C or internal Li-Po battery	
▪ battery	11.1 Wh capacity 80% charge in 2.5 hours, full charge in 3 hours.	
▪ communication	Bluetooth (4.0 - Dual-Mode) or USB Type-C port (recommended USB cable: supplied shielded USB-C to USB-A cable)	
▪ housing	aluminum body: 11.4 x 8.0 x 4.5 cm	
▪ weight	+/- 500 g	
▪ internal storage space	500 MB, equivalent to >15M datapoints	

Specifications are subject to change, due to regular firmware updates. See the EmStat4X product page on our website for accurate and detailed specifications.

5 Troubleshooting

5.1 Verifying your potentiostat

Your instrument can be tested by using the test sensor or dummy cell supplied with the instrument.

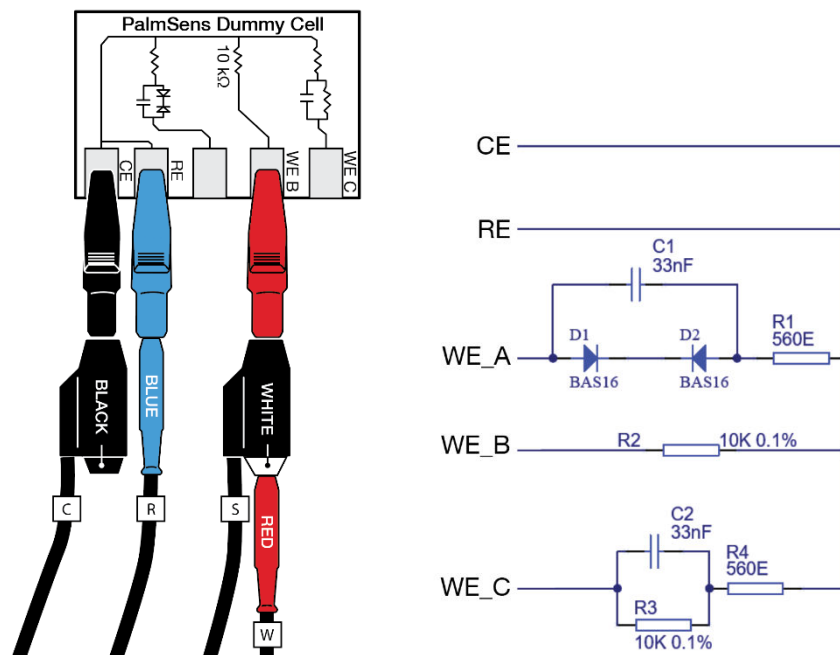

Figure 6 PalmSens Dummy Cell

The easiest way to verify the functioning of your instrument is to use the “WE B” circuit, which consists of a resistor with a value of 10 kΩ with a max deviation of 0.1%.

The WE lead is connected to one side and both RE and CE to the other side of the resistor. In case you are using the EmStat4X HR: Make sure to connect the sense lead to the WE lead as well.



Make sure to stack the sense lead with the WE lead when connecting it to the dummy cell.

Any of the electrochemical techniques can be applied. The current response obtained with a resistor with value R is equal to the applied potential or potential pulse divided by the value of R . So, if a potential of 0.5 V is applied on a resistor of 10 k Ω , the obtained current should be $0.5 \text{ V} / 10 \text{ k}\Omega = 50 \text{ }\mu\text{A}$.

Contact PalmSens BV if the problems are found: info@palmsens.com and report the problems as detailed as possible.

5.2 Noise

Our instruments are designed with hardware noise suppression filters to reject noise from internal and external sources. If a higher level of noise is your issue, the solving strategies are rather numerous, but the sources for noise are also numerous. Here we describe the most successful and common methods for noise reduction.

To determine the noise levels for your instrument, please refer to section "Measuring the noise level of the instrument" in the PSTrace Manual.

5.2.1 Power grid

Your power grid is usually using an alternating current. This undulating current influences the measured currents. PSTrace and PStouch have a filter for this mains frequency. In PSTrace, check in the 'Tools' menu under 'General Settings' if the mains frequency is set correctly (50 Hz or 60 Hz).

5.2.2 Electrical fields

Our environment is filled with electrical fields. Some of them are created by devices around us as side effects or in case of wireless communication on purpose. Although it is a bad idea to measure directly next to an electric arc furnace, it is usually not possible to have a workspace free of electrical fields, especially not during point-of-care measurements.

Nearby RF transmitters (Wi-Fi routers, mobile phones, industrial radios) may be interpreted by the instrument as valid electrochemical signals. Measurements performed near such sources may therefore deviate from stated specifications.

A Faraday cage is usually sufficient to create a field-free environment. A metal box or cage out of metal mesh is a good Faraday cage. Even a shield out of aluminum foil can help. Place your electrochemical cell inside the Faraday cage and connect the cage to the ground lead (green) of the potentiostat. The cable delivered with your instrument has an inbuilt shield and should protect your signal outside the Faraday cage. This is one of the most effective methods to reduce noise.

5.2.3 Cables

Cables should not be unnecessarily long, since they act as antennas for noise, but the cable delivered with your instrument has an inbuilt shield and as long as you use the original cable, there is little reason to worry about cable induced noise.

5.2.4 Contacts

Check if the contacts are corroded. If so, remove the stains, for example with sandpaper.

6 Maintenance and compliance

6.1 Lithium-Polymer batteries

The typical estimated life of a Lithium-Polymer battery is about two to three years or 300 to 500 charge cycles, whichever occurs first. One charge cycle is a period of use from fully charged, to fully discharged, and fully recharged again. Consider a two-to-three-year life expectancy for batteries that do not run through complete charge cycles.

Rechargeable Lithium-Polymer batteries have a limited life and will gradually lose their capacity to hold a charge. This loss of capacity (aging) is irreversible. As the battery loses capacity, the length of time it will power the product (run time) decreases. Lithium-Ion batteries continue to slowly discharge (self-discharge) when not in use or while in storage.

Detailed instructions for battery replacement can be found in this document.

The new battery or battery pack must be obtained from PalmSens BV. Lithium-ion batteries have specific voltage operation and temperature control requirements, so using the wrong model may lead to overheating and fire.



The use of an unauthorized battery may compromise safety, pose a risk of fire, and result in irreversible damage to the device.

6.2 Temperature compliance

Our instruments are designed for indoor use at ambient temperatures between 0 °C and 45 °C. All the components of PalmSens products (except their batteries) are rated to the industrial temperature standard of -40 °C to +85 °C.

The battery of the EmStat4X is rated -20 °C to +60 °C when discharging 0 °C to +45 °C when charging.

6.3 Humidity compliance

PalmSens instruments have not been tested in high humidity environments.

Elevated humidity however may cause measurement errors if condensation forms on the electronics. This affects measurements in the nA ranges or lower. Prolonged exposure to a condensing environment may severely decrease the life expectancy of the instrument and void its warranty.

6.4 Temperature drift

PalmSens instruments are calibrated at 21 °C. The most sensitive components of the instrument have temperature drift of 50 ppm. For instance at 1 °C or 41 °C, measurement drift of up to 0.1% may be experienced.

6.5 Atmospheric pressure

PalmSens instruments are not intended for use in safety-critical applications. Consequently, the power supplies utilized are not selected based on a specific pressure rating.

6.6 Cleaning

Make sure to disconnect your instrument from any cell or power source, if applicable, prior to cleaning. Use a cloth lightly dampened with either clean water or water containing a mild detergent to clean the outside of the instrument. Alternatively, you can use isopropyl alcohol. Avoid using a wet rag and prevent any fluids from entering the instrument. It is crucial not to immerse the instrument in any cleaning solution.

6.7 Periodic calibration and preventive maintenance

PalmSens instruments are designed in a way that eliminates the need for periodic calibration. While not mandatory, PalmSens does provide a calibration service for users with specific demands such as QC/ISO purposes. This service includes a new calibration certificate.

It's important to note that PalmSens instruments do not require preventive maintenance, further simplifying their use and reducing the overall maintenance demands on users.

6.8 Service and repair

Except for the battery in some models, your PalmSens instrument contains no user-serviceable parts internally. Any service or maintenance needs should be directed to a qualified service technician employed by PalmSens BV. Attempting to access or modify internal components without proper expertise may result in additional damage to the instrument and void warranties. It is recommended to rely on authorized service personnel for any required maintenance or repairs.

6.9 RoHS Compliance

All instruments from PalmSens have been built using lead free components and lead-free solder. They are in compliance with the European RoHS initiative.

A. EU Declaration of conformity



EU DECLARATION OF CONFORMITY

Certificate number: PSDOC-ES4X-B



Manufacturer: PalmSens BV
Address: Vleugelboot 22,
3991 CL Houten,
The Netherlands

This declaration is valid for the following product:

EmStat4X, Portable electrochemical analyser

- USB power and communications
- Battery power
- Bluetooth communication
- Screen display
- 1 meter cell cable

The object of the declaration described above is in conformity with the Radio Emissions Directive 2014/53/EU (RED) and applicable standards listed below:

Health & Safety

- EN 62479
- EN 61010-1

EMC

- EN 61326-1
- EN 301 489 parts 1 & 17

Efficient Usage of Radio Spectrum

- EN 300 328

This declaration is issued under the sole responsibility of PalmSens BV.

Date: 29th of November 2023

A handwritten signature in black ink, appearing to read "C.J. van Velzen".

C.J. van Velzen, CTO

B. EU Waste Electrical and Electronic Equipment (WEEE) Directive



The pictogram shown above, located on the product(s) and / or accompanying documents means that used electrical and electronic equipment (WEEE) should not be mixed with general household waste. For proper treatment, recovery and recycling, please take this product(s) to designated collection points where it will be accepted free of charge.

Alternatively, in some countries, you may be able to return your products to your local retailer upon purchase of an equivalent new product. Disposing of this product correctly will help save valuable resources and prevent any potential negative effects on human health and the environment, which could otherwise arise from inappropriate waste handling. Please contact your local authority for further details of your nearest designated collection point. Penalties may be applicable for incorrect disposal of this waste, in accordance with your national legislation.

Published by

PalmSens BV
Vleugelboot 22
3991 CL Houten
The Netherlands

© 2026 PalmSens BV
All rights reserved.

